

SECTION B-B

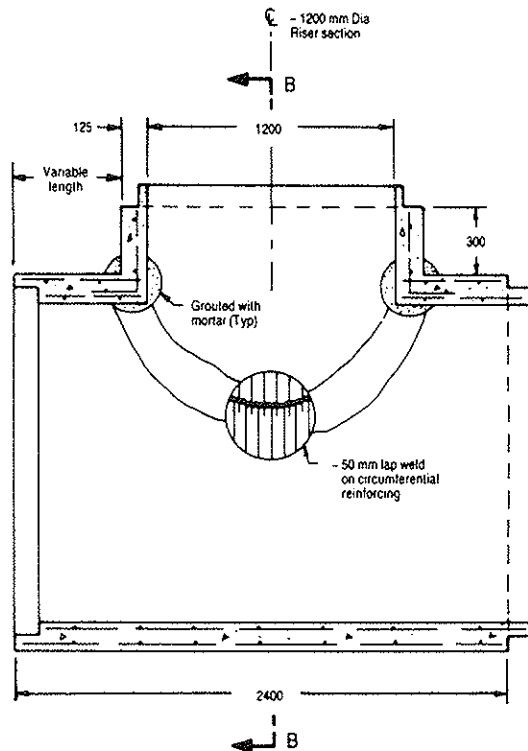

SECTION A-A

NOTES:

- A Minimum sewer size: 1200 mm Dia.
- B Manhole to be completed with standard 1200 mm Dia riser section.
- C Manhole tee and precast riser section to conform to ASTM-C-478.
- D Sewer pipe to conform to CSA A 257*2 standard.
- E Horizontal section available from 1200 to 3000 mm Dia.
- F Reinforced as per CSA A257*2.
- G Ladder rungs as required.
- H All dimensions are in millimetres.



CONCAST

R.R. #3, Guelph, Ontario N1H 6H9
Tel: 1-800-668-PIPE (7473)

CON CAST PIPE

No. 707.01

**PRECAST CONCRETE
MAINTENANCE HOLE TEE**