

STENCIL
 CCP-GUELPH
 1606 x 1206 x 203
 PEEL STD
 TYPE HSb
 DATE OF MFG
 1031 KG

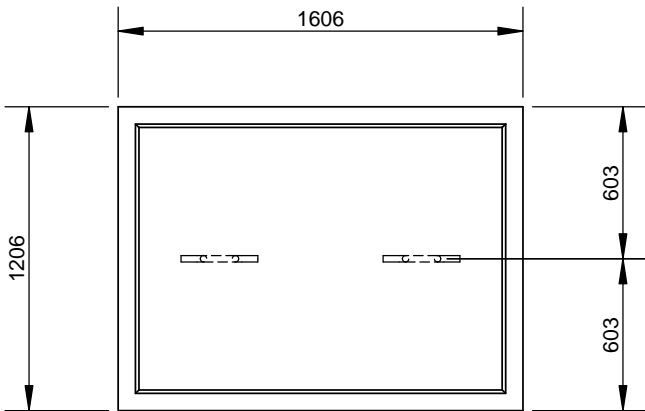

PLAN VIEW

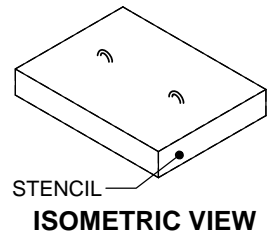
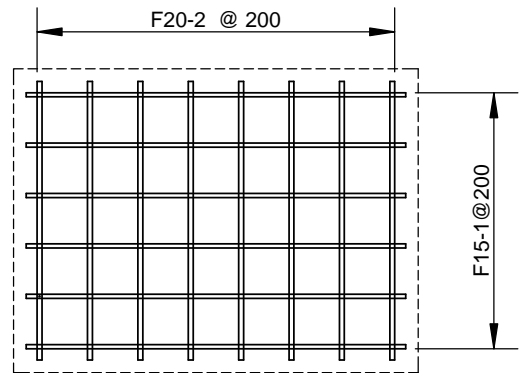

**PLAN VIEW
 (LOWER LAYER REINFORCING)**

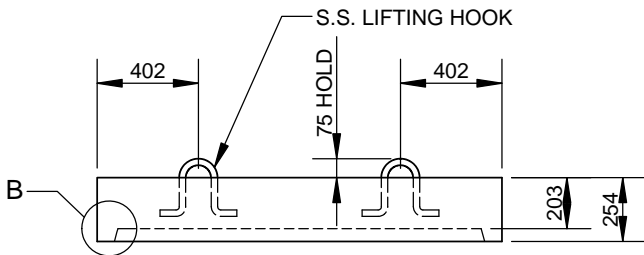

ELEVATION VIEW

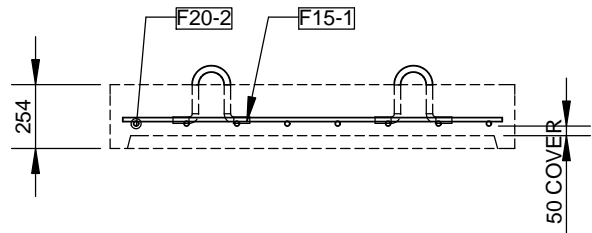

**ELEVATION VIEW
 (REINFORCEMENT)**

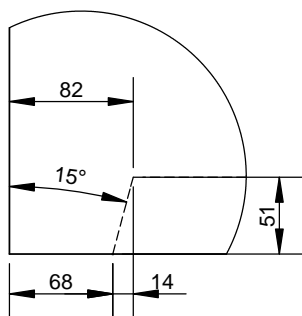

DETAIL B

CAST IN MATERIAL LIST		
PART ID	QTY	DESCRIPTION
RLZ004	2	1" S.S. LIFTING HOOK

REINFORCING LIST				
MARK	SIZE	QTY.	LENGTH	SHAPE
F15-1	15M	6	1506	STR.
F20-2	20M	8	1106	STR.

ENGINEER STAMP (IF REQUIRED)

ALL DIMENSIONS ARE IN mm
 DRAWINGS ARE NOT TO SCALE
 ALL VIEW AS POURED UNLESS SPECIFIED
 EXPOSURE CLASS = C1 AS PER CSA A23.4-09
 WWF SHEETS TO CSA G.30.5 AND CSA G.30.15
 WWF Fy = 485MPa (Deformed) 450MPa (Smooth)
 REINFORCING TO CSA G.30.18 GRADE 400W
 TACK WELD CAGE FOR HANDLING ONLY
 NO STRUCTURAL WELDS REQUIRED

MIN. CONC STRENGTH 40 MPa
 CLEAR COVER = 50 mm ± 10 mm
 TOLERANCES TO CSA A23.4-09
 APPROX. MASS 1031 kg
 STRIP CONC. STRENGTH 20 MPa
 AIR ENTRAINMENT 5 % TO 8 %

CON CAST PIPE (CCP) STANDARD DRAWING

STD. PEEL STD 1-1-6 REV# NOV 2011 PART SLAB161202

TITLE
**PEEL REMOVABLE SLAB
 1606 X 1206 X 203
 REGISTRY DRAWING**

2	REVISED STENCIL DETAIL	RM	24/NOV/2014
1	ISSUED REGISTRY DRAWING	MDT	21/JAN/2014
REV.	DESCRIPTION	ENG.	DATE

DRAWN BY MDT	CHECKED BY SW	DATE 21/JAN/2014	FILE PEEL REMOVABLE SLAB REINF REV1
-----------------	------------------	---------------------	--